

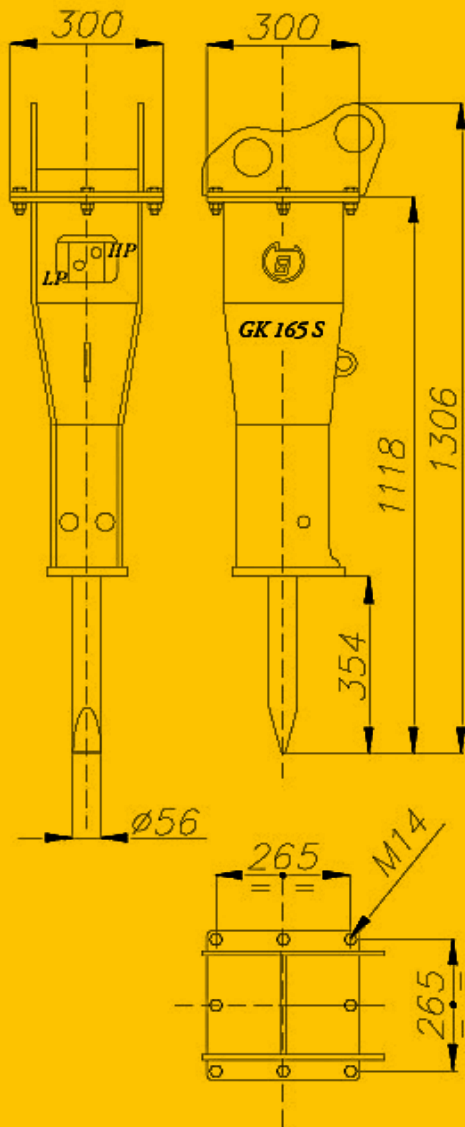

Italdem®



GK-165 S

HYDRAULIC BREAKER

OPERATING WEIGHT	155 KG
TOOL DIAMETER	56 MM
OIL FLOW	25÷40 L/MIN
WORKING PRESSURE	95÷105 BAR
RELIEF VALVE	140 BAR
MAX BACKPRESSURE	12 BAR
BLOW ENERGY	350 JOULE
REQUIRED POWER	9,5 HP
IMPACT RATE	670÷1050
CARRIER WEIGHT	2÷4,5 TON
MAX NOISE LEVEL (SILENCED)	90 DB-A
INNER DIAMETER HP LINE	16 MM
INNER DIAMETER LP LINE	20 MM

www.italdem.com