

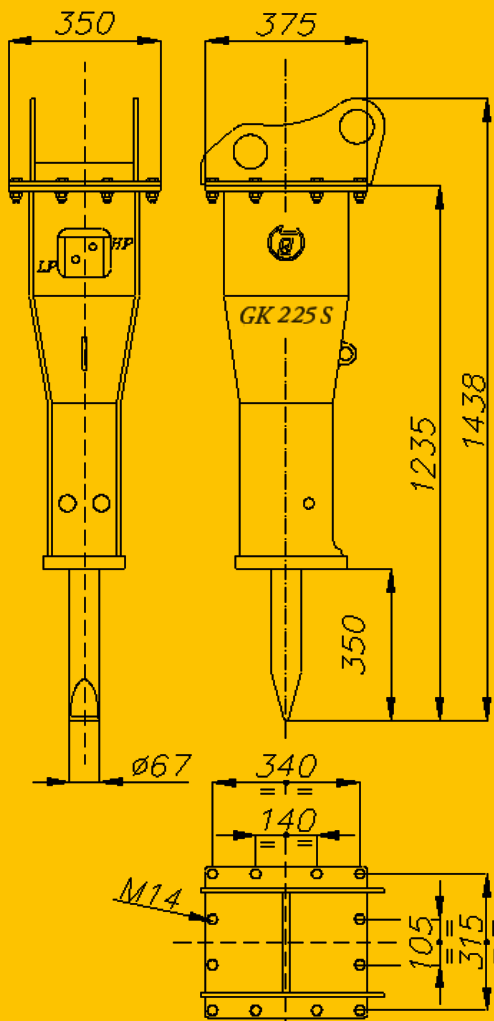

Italdem®



GK-225 S HYDRAULIC BREAKER

OPERATING WEIGHT	220 KG
TOOL DIAMETER	67 MM
OIL FLOW	35÷60 L/MIN
WORKING PRESSURE	95÷105 BAR
RELIEF VALVE	140 BAR
MAX BACKPRESSURE	12 BAR
BLOW ENERGY	520 JOULE
REQUIRED POWER	14 HP
IMPACT RATE	620÷1050
CARRIER WEIGHT	3÷6 TON
MAX NOISE LEVEL (SILENCED)	90 DB-A
INNER DIAMETER HP LINE	20 MM
INNER DIAMETER LP LINE	26 MM

www.italdem.com