

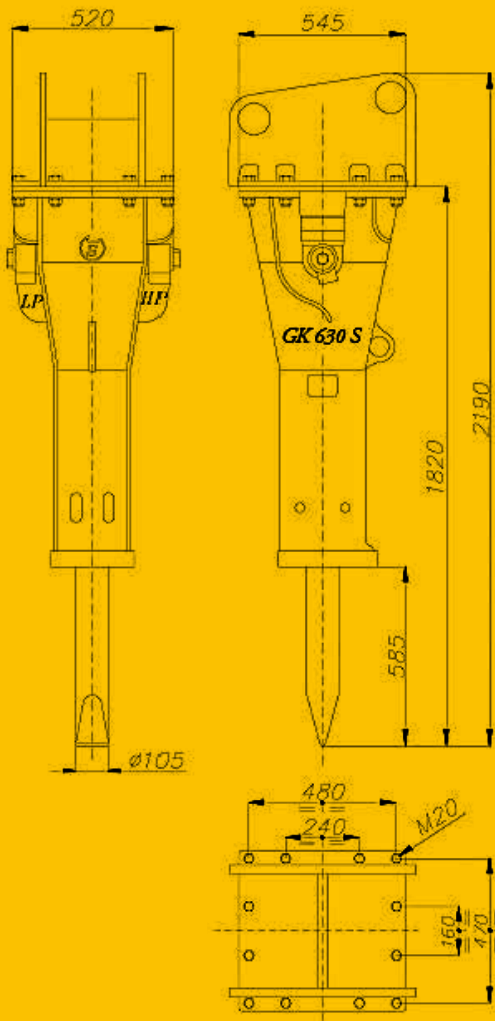

Italdem®

GK-630 S HYDRAULIC BREAKER



OPERATING WEIGHT	650 KG
TOOL DIAMETER	105 MM
OIL FLOW	110÷130 L/MIN
WORKING PRESSURE	110÷120 BAR
RELIEF VALVE	170 BAR
MAX BACKPRESSURE	12 BAR
BLOW ENERGY	1700 JOULE
REQUIRED POWER	35 HP
IMPACT RATE	600÷650
CARRIER WEIGHT	9÷15 TON
MAX NOISE LEVEL (SILENCED)	88 DB-A
INNER DIAMETER HP LINE	20 MM
INNER DIAMETER LP LINE	36 MM

www.italdem.com