

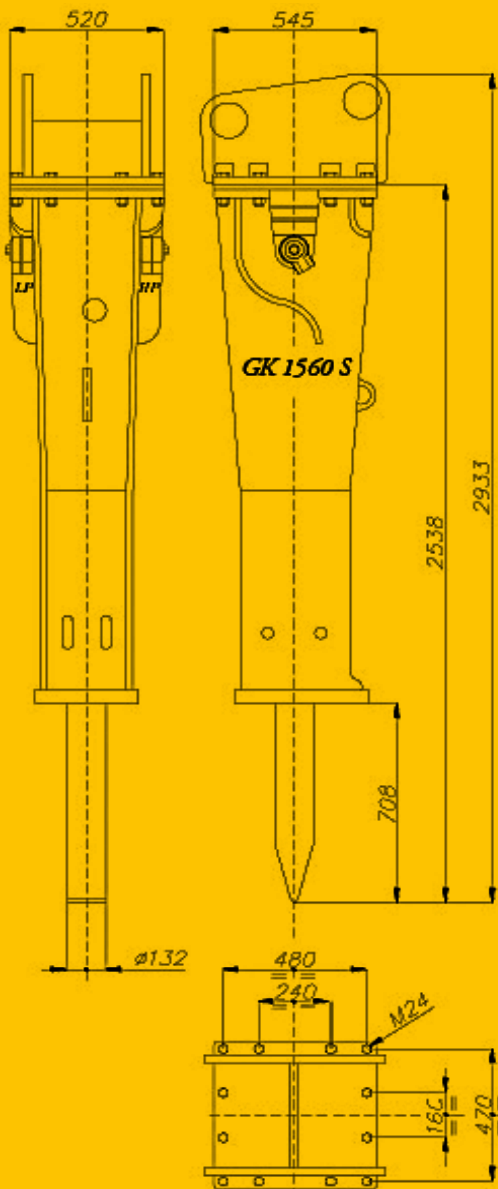

Italdem®

GK-1560 S HYDRAULIC BREAKER



OPERATING WEIGHT	1500 KG
TOOL DIAMETER	132 MM
OIL FLOW	160÷170 L/MIN
WORKING PRESSURE	140÷150 BAR
RELIEF VALVE	200 BAR
MAX BACKPRESSURE	12 BAR
BLOW ENERGY	3500 JOULE
REQUIRED POWER	56 HP
IMPACT RATE	580 (700)
CARRIER WEIGHT	20÷28 TON
MAX NOISE LEVEL (SILENCED)	88 DB-A
INNER DIAMETER HP LINE	26 MM
INNER DIAMETER LP LINE	38 MM

www.italdem.com