

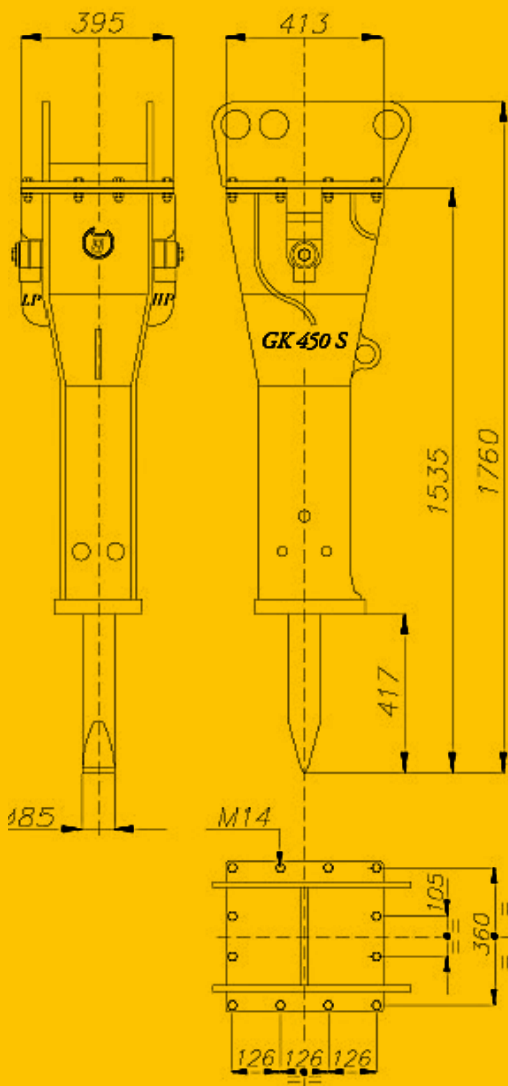

Italdem®

GK-450 S HYDRAULIC BREAKER

OPERATING WEIGHT	450 KG
TOOL DIAMETER	85 MM
OIL FLOW	75÷100 L/MIN
WORKING PRESSURE	105÷115 BAR
RELIEF VALVE	150 BAR
MAX BACKPRESSURE	12 BAR
BLOW ENERGY	1050 JOULE
REQUIRED POWER	25,5 HP
IMPACT RATE	650÷900
CARRIER WEIGHT	7÷11 TON
MAX NOISE LEVEL (SILENCED)	90 DB-A
INNER DIAMETER HP LINE	20 MM
INNER DIAMETER LP LINE	30 MM



www.italdem.com